

Model 450AJ

ARTICULATING BOOM LIFT



ENVIRONMENTALLY FRIENDLY

- Variable speed engine control for improved fuel efficiency reducing operating cost.

POWER & PERFORMANCE

- 50%* faster full elevation time (* actuals might vary) increasing workers efficiency.

MORE ACCESS

- More horizontal reach for an increased work envelope.

GREATER STRENGTH

- 250 kg in basket vs 230 kg before allowing you to carry more tools or materials to stay on a job longer.

Standard Features

- 1.24m (4ft 1in) Articulating Jib
- Platform 0.76m x 1.83m (30in x 72in) Side Entry
- 180 Degree Hydraulic Platform Rotator
- Platform Console Machine Status Light Panel¹
- AC cable to Platform
- 5 Degree Tilt Alarm/Indicator Light
- Swing Out Engine Module
- Improved Multi-Function Controls
- Dura Tough gull-wing turntable hoods
- 12V-DC Auxiliary Power
- Hourmeter
- Interactive Display at Ground Controls
- Proportional Controls
- Control ADE[®] System
- Lifting/Tie Down Lugs
- Horn
- Four-Wheel Hydrostatic Drive
- Oscillating Axle
- Cast Aluminum Control Box
- Motion Alarm
- Reduced Time to Full Height

Standard Specifications

Power Source	
• Diesel Engine	
• Deutz D2.3 L3 Stage IIIA	36.4 kW
• Fuel Tank Capacity	60.5 L
Hydraulic System	
• System Capacity	144 L
• Tank Capacity	136 L
• Auxiliary Power	12V-DC
Tyres	
• Standard	33/1550 x 16.5 Foam Filled Superwide tyres
• Optional	315/55 D20 foam filled tyres Non-Marking Tires

Accessories & Options

- 0.76m x 1.22m (30 x 60in) Platform
- Inward Self-Closing Swing
- 0.76m x 1.22m (30 x 48in) Platform
- 13mm (1/2 in) Air Line to Platform
- AC Generator
- Flashing Amber Beacon
- Hostile Environment Kit²
- Light Package
- Platform Worklights
- Operator Tool Tray
- Accessory Packages
- SkyPower[®] Package
- SkyGuard[®]
- PipeRack
- Catalytic exhaust purifier

¹. Includes boom wipers, cylinder bellows and console cover.

Note: Some options may increase lead time, and some option combinations may not be available.

Model 450AJ

ARTICULATING BOOM LIFT

Performance

• Platform Height	13.72 m
• Horizontal Outreach	7.62 m
• Up and Over Height	7.3 m
• Swing	355 Degrees Non-Continuous
• Platform Capacity	250 kg
Unrestricted	250 kg
• Platform Size	0.76 x 1.83 m
• Platform Rotator	180 Degrees Hydraulic
• Jib	1.24 m
• Range of Articulation	144 Degrees (+76, -69)
• Weight	6,495 kg
• Max Ground Bearing Pressure (With Pneumatic Tires)	4 kg/cm ²
• Drive Speed	6.8 km/h
• Gradeability	45%
• Axle Oscillation	10 cm
• Turning Radius	
Inside	2.06 m
Outside	4.78 m



Reach Diagram

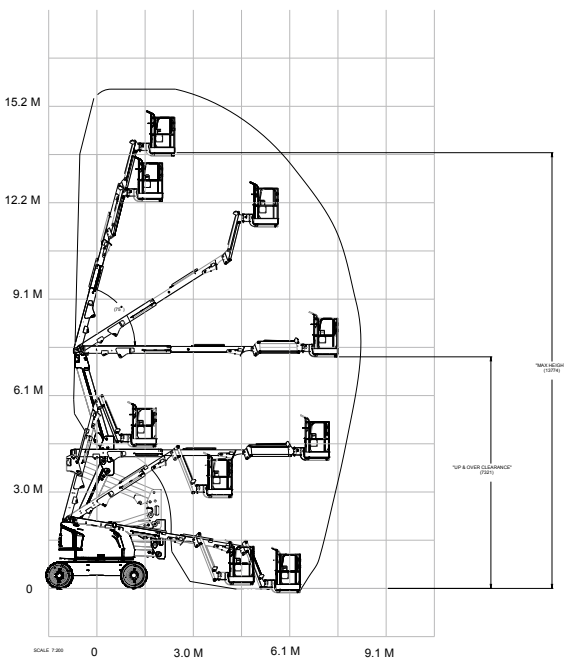

Dimensions

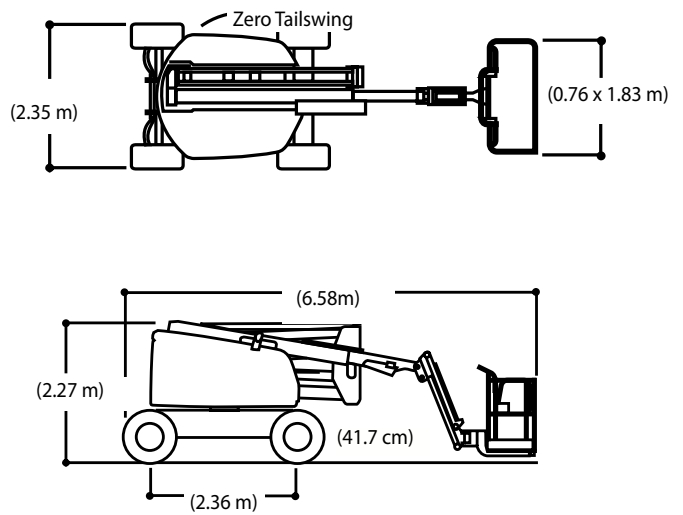

IMPORTANT

JLG is continually researching and developing products and reserves the right to make modifications without prior notice. All data in this document is indicative. Certain options or country standards will increase weight. Specifications may change to meet country standards or with the addition of optional equipment.

Due to continuous product improvements, JLG Industries reserves the right to make specification and/or equipment changes without prior notification.



JLG EMEA BV

Polaris Avenue 63
2132 JH Hoofddorp
The Netherlands
Tel: +31 (0)23 565 5665
Fax: +31 (0)23 557 3750
www.jlg.com

An Oshkosh Corporation Company