

Model 1500AJP

ARTICULATING BOOM LIFTS



PRODUCTIVITY REDEFINED

- World's largest working envelope with high capacity throughout
- JLG QuickStick™ capability allows for full height to ground in ~2 minutes
- Pivoting axles deploy in ~1 minute
- Full height drive capability

OPERATOR CONFIDENCE

- Cylinder deployed pivoting axles create wide footprint
- LCD display keeps operator fully informed on location in work envelope
- Advanced hydraulics and cylinder dampening provides for smooth ride

TRANSPORTABLE

- Fits most standard trailers

Standard Features

- 0.91 x 2.44 m Platform
- Articulating Jib
- Dual Rated Capacities (270 kg / 450 kg)
- Drive-Out Extendable Axles
- 180° Hydraulic Platform Rotator
- AC Receptacle in Platform
- Tilt Light and Alarm
- Swing-Out Engine Tray
- 12V-DC Auxiliary Power
- Hourmeter
- Control ADE® System
- Hydrostatic Drive
- Proportional Controls
- Gull-Wing Steel Hoods
- Platform Console Machine Status Light Panel²
- Lifting/Tie Down Lugs
- Engine Distress Warning/Shutdown-Selectable via JLG Analyzer
- All Motion Alarm
- LCD Panel at Operator's Platform Control Console
- Quik Stik®
- Tool Tray
- JLG Skyguard active system

2. Provides indicator lights at platform control console for system distress, fuel level, low fuel, 5 degree tilt light and foot switch status.

Standard Specifications

Power Source	
• Diesel Engine Deutz TCD 3.6 T4F	74.4 kW
• Fuel Tank Capacity	170 L
Hydraulic System	
• Hydraulic Tank Capacity	352 L
Tyres	
• Standard	445/50D710 24 ply Foam-Filled

Accessories & Options

- Diesel Engine Deutz TCD 3.6 LRC
- 36 x 72 in. (.91 x 1.83 m) Platform
- Inward Self-Closing Swing Gate
- Light Package³
- Soft Touch System
- Cold Weather Start Kit⁴
- Hostile Environment Kit⁵
- Flashing Amber Beacon
- Cold Package Plus⁶
- Special Hydraulic Oils
- Skyguard beacon (ILOS)
- Accessory Packages:
 - SkyAir®
 - SkyWelder®
 - SkyGlazier®
 - SkyPower® Package - 7500 Watt Generator Power Cable to Platform

3. Includes platform mounted worklights and drive/backup lights.

4. Includes engine block heater, battery heater and oil tank heater.

5. Includes console cover, boom wipers and cylinder bellows.

6. Includes extreme cold engine oil, fuel conditioner, engine block heater, battery blanket, glow plugs, hydraulic tank heater, oversized footswitch and arctic hydraulic oil priced separately

Model 1500AJP

ARTICULATING BOOM LIFTS

Performance

• Working Height	48.15 m
• Working Outreach	23.55 m
• Up and Over Height	18.40 m
• Swing	360° Continuous
• Platform Capacity-Restricted	450 kg
• Platform Capacity-Unrestricted	270 kg
• Platform Rotator	180° Hydraulic
• Jib Length	2.44 m
• Jib Range of Articulation	130° (+75, -55)
• Jib Horizontal Rotation	125° (55 right, 70 left)
A. Platform Size	0.91 m x 2.44 m
B ¹ . Overall Width (Axles Retracted)	2.50 m
B ² . Overall Width (Axles Extended)	5.00 m
C. Tailswing (working condition)	0.70 m
D. Stowed Height	3.10 m
E ¹ . Stowed Length	15.10 m
E ² . Stowed Length (transport position)	12.10 m
F. Wheelbase (axles extended)	4.60 m
G. Ground Clearance	0.30 m
• Weight ¹	26,027 kg
• Max. Ground Bearing Pressure	7.03 kg/cm ² TBD
• Drive Speed	4.5 km/h
• Gradeability	40%
• Turning Radius (Inside)	
• Axles Retracted	7.10 m
• Axles Extended	2.30 m
• Turning Radius (Outside)	
• Axles Retracted	9.50 m
• Axles Extended	6.60 m

¹ Certain options or country standards may increase weight and/or dimensions.



Reach Diagram

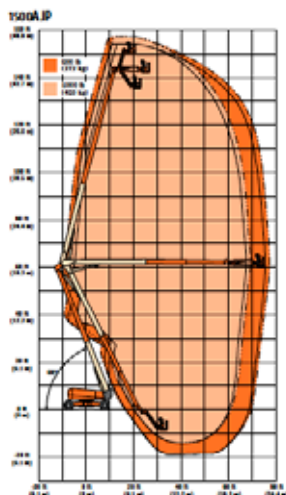

Dimensions

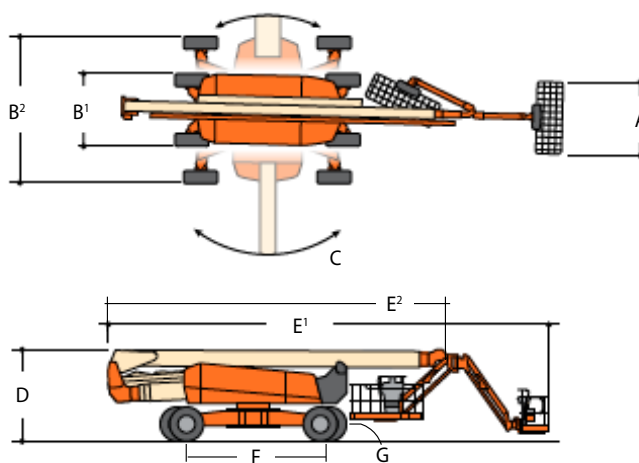

IMPORTANT

JLG is continually researching and developing products and reserves the right to make modifications without prior notice. All data in this document is indicative. Certain options or country standards will increase weight. Specifications may change to meet country standards or with the addition of optional equipment.

Due to continuous product improvements, JLG Industries reserves the right to make specification and/or equipment changes without prior notification.



JLG EMEA BV

Polaris Avenue 63
2132 JH Hoofddorp
The Netherlands
Tel: +31 (0)23 565 5665
Fax: +31 (0)23 557 3750
www.jlg.com

An Oshkosh Corporation Company